

MATHLETICS

D

Student Book

SERIES

Measurement



Name _____

Series D – Measurement

Contents

Topic 1 – Units of length (pp. 1–9)

Date completed

- metres _____
- centimetres _____
- metres and centimetres _____
- millimetres _____
- perimeter _____
- length and decimal notation _____
- connect and block – *apply* _____

Topic 2 – Area (pp. 10–15)

- square centimetres _____
- square metres _____
- area challenges – *apply* _____
- tangram areas – *solve* _____

Topic 3 – Volume and capacity (pp. 16–20)

- litres _____
- millilitres _____
- measuring volume with cubic centimetres _____
- counting cubes – *investigate* _____

Topic 4 – Mass (pp. 21–25)

- kilograms _____
- grams _____
- mystery mass – *solve* _____

Series Author:

Nicola Herringer

Units of length – metres

We use metres to measure length.

There are 100 centimetres in a metre.

$$100 \text{ cm} = 1 \text{ m}$$

1 Convert these metres to centimetres:

a $6 \text{ m} = \boxed{} \text{ cm}$

b $3 \text{ m} = \boxed{} \text{ cm}$

c $9 \text{ m} = \boxed{} \text{ cm}$

2 Estimate and then measure the length and width of these objects:

	Object		Estimate in metres	Measurement in metres
a	classroom	length	<input type="text"/> m	<input type="text"/> m
		width	<input type="text"/> m	<input type="text"/> m
b	whiteboard	length	<input type="text"/> m	<input type="text"/> m
		width	<input type="text"/> m	<input type="text"/> m
c	desk	length	<input type="text"/> m	<input type="text"/> m
		width	<input type="text"/> m	<input type="text"/> m

3 Find out how tall each animal is to the nearest metre:

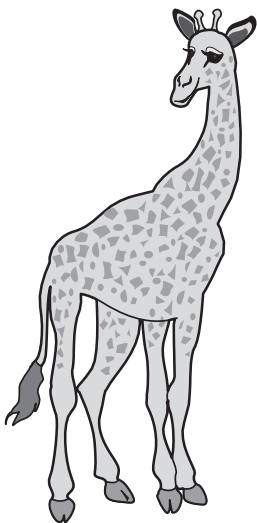

a m

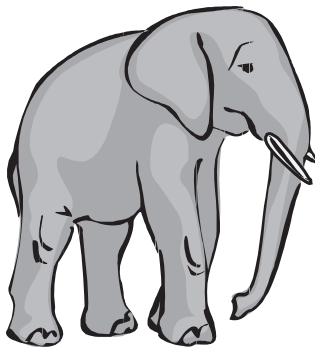

b m

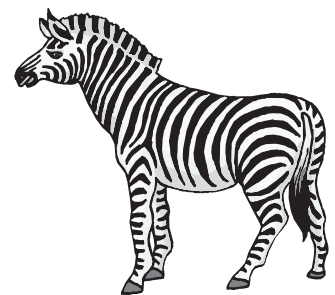

c m

Units of length – centimetres

We use centimetres to measure smaller units of length.

There are 100 centimetres in a metre.

$$100 \text{ cm} = 1 \text{ m}$$

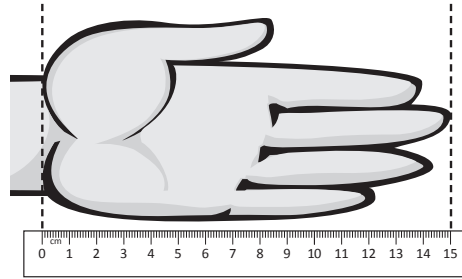

1 Record the lengths shown on this ruler in each box:

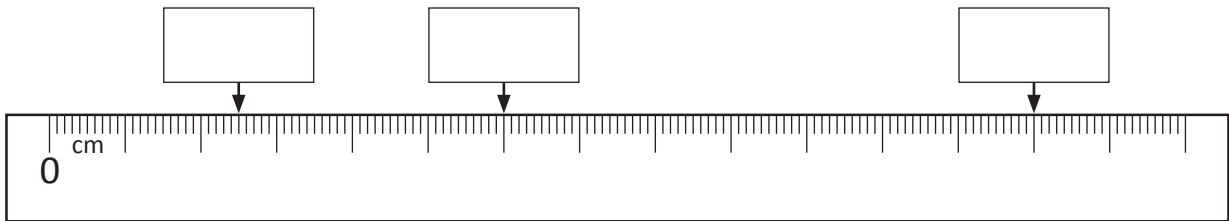

2 Use a ruler to draw the following lines. Start at the dot.

- a 7 cm •
- b 8 cm •
- c 11 cm •
- d 3 cm •

3 Measure these parts of your body with a piece of string. Lay the string beside a metre ruler to work out the correct measurement for each.

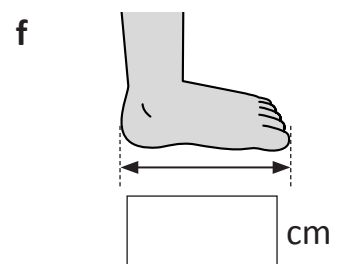
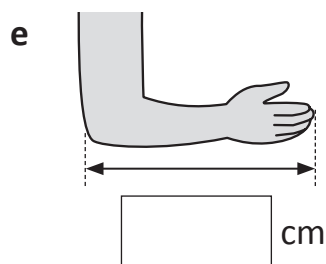
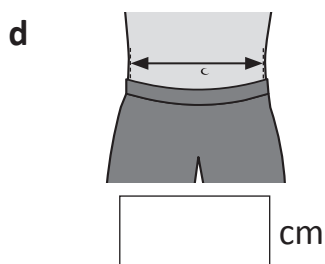
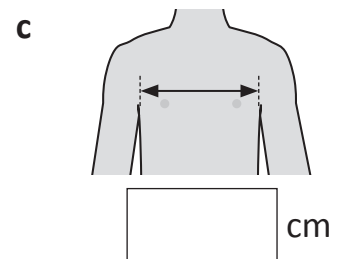
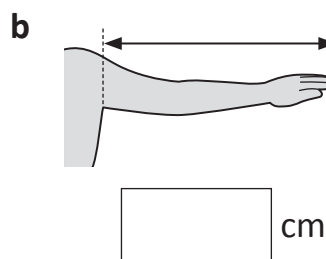
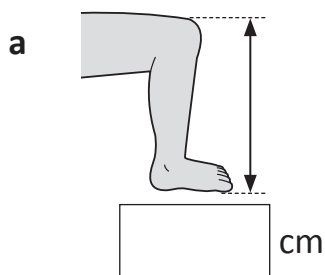

Units of length – metres and centimetres

Often we will use both metres and centimetres when measuring length. This length of ribbon is 146 cm. This is 1 metre and 46 centimetres.



1 Write these lengths in centimetres:

- a 1 m 38 cm cm b 1 m 67 cm cm c 2 m 82 cm cm
d 5 m 45 cm cm e 4 m 59 cm cm f 2 m 90 cm cm

2 Write these lengths as metres and centimetres:

- a 217 cm m cm b 391 cm m cm
c 462 cm m cm d 113 cm m cm
e 835 cm m cm f 194 cm m cm

3 Work out the missing lengths that make up each metre:

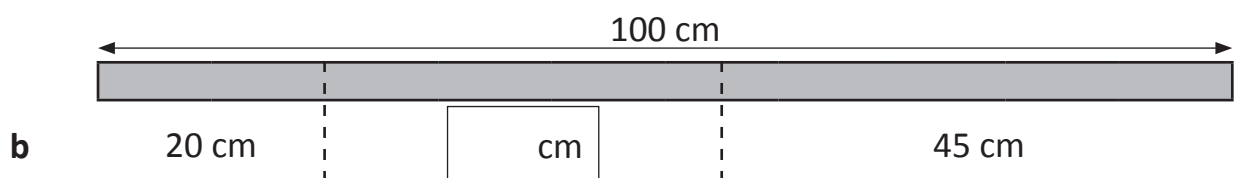
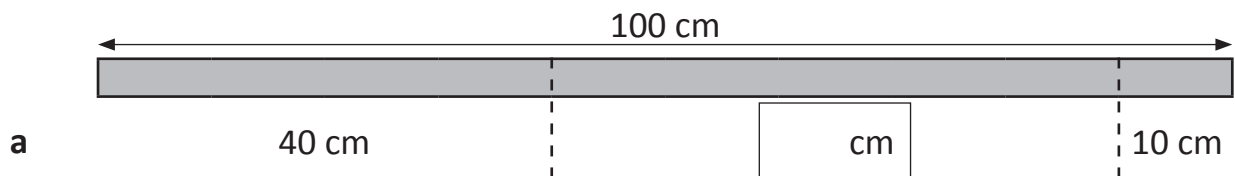

4 Fill in the gaps using 'm' or 'cm':

- a Hassan is 113 tall. b The house is 5 taller than the car.
c Natasha only lives 79 from school. d Lisa measured her waist size and it was 64 .

Units of length – millimetres

When we need a unit of length that is smaller than a centimetre, we use millimetres. There are 10 millimetres in 1 centimetre. $10 \text{ mm} = 1 \text{ cm}$

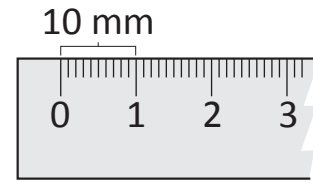

1 Estimate and measure these objects in millimetres:

Object	Estimate	Millimetres
a Width of your thumb		
b Length of your hand		
c Length of a cornflake		

2 How many millimetres in:

a $4 \text{ cm} = \square \text{ mm}$

b $9 \text{ cm} = \square \text{ mm}$

c $2 \text{ cm} = \square \text{ mm}$

3 Write these measurements in centimetres:

a $40 \text{ mm} = \square \text{ cm}$

b $70 \text{ mm} = \square \text{ cm}$

c $30 \text{ mm} = \square \text{ cm}$

4 Record the length of each piece of string in millimetres:

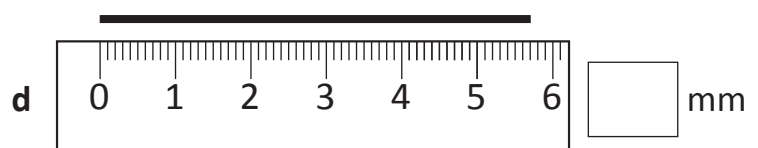
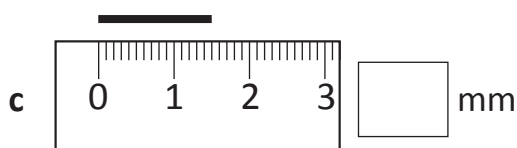
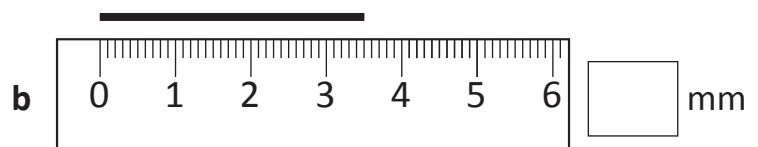
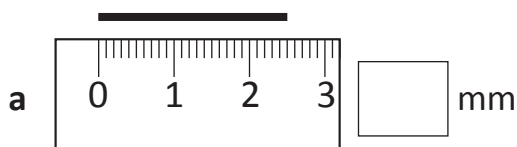

Units of length – millimetres

5 Measure the height of each mini-mathlete in millimetres:

a



Height _____

b



Height _____

c



Height _____

d

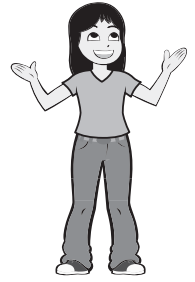

Height _____

6 Write these lengths in millimetres:

a 1 cm 5 mm = mm

b 5 cm 7 mm = mm

c 4 cm 8 mm = mm

d 1 cm 9 mm = mm

e 8 cm 3 mm = mm

f 2 cm 4 mm = mm

7 Write these lengths as centimetres and millimetres. The first one has been done for you.

a 63 mm =

b 84 mm =

c 27 mm =

d 19 mm =

e 53 mm =

f 36 mm =

8 Measure these parts of the picture in millimetres:



a Height of the door mm

b Width of the house mm

c Height of the fence mm

d Width of the garage door mm

Units of length – perimeter

The perimeter is the total length around the outside of an enclosed space.
To find the perimeter of this shape, we add the lengths of all the sides.

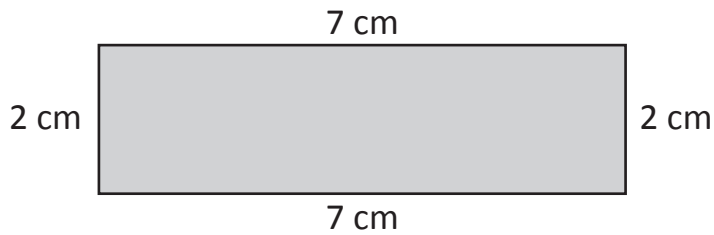

$$P = 7 + 2 + 7 + 2$$
$$= 18 \text{ cm}$$

1 Find the perimeters of these shapes.

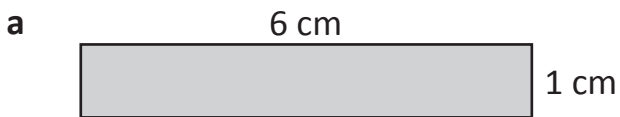

$$P = \underline{\quad} + \underline{\quad} + \underline{\quad} + \underline{\quad}$$
$$= \underline{\hspace{2cm}}$$

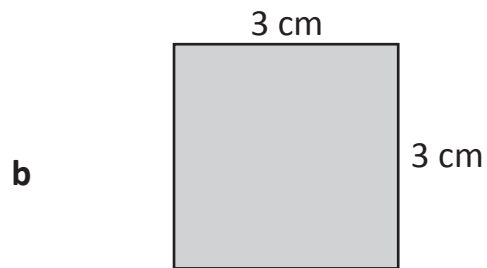

$$P = \underline{\quad} + \underline{\quad} + \underline{\quad} + \underline{\quad}$$
$$= \underline{\hspace{2cm}}$$

2 Measure these shapes and find the perimeter.

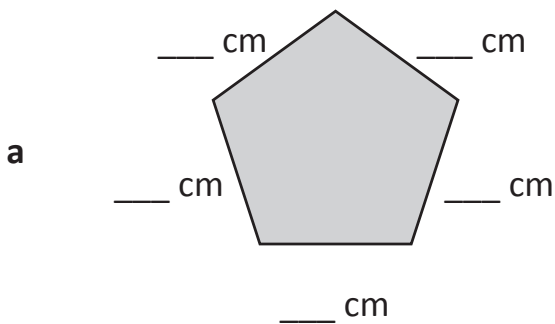

$$P = \underline{\quad} + \underline{\quad} + \underline{\quad} + \underline{\quad} + \underline{\quad}$$
$$= \underline{\hspace{2cm}}$$

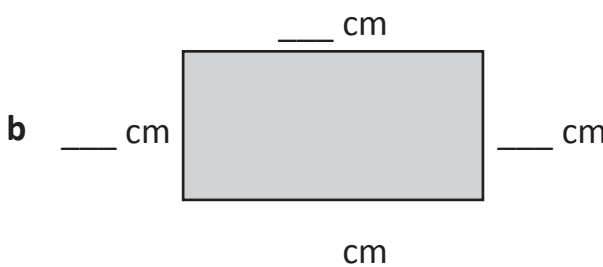

$$P = \underline{\quad} + \underline{\quad} + \underline{\quad} + \underline{\quad}$$
$$= \underline{\hspace{2cm}}$$

Units of length – length and decimal notation

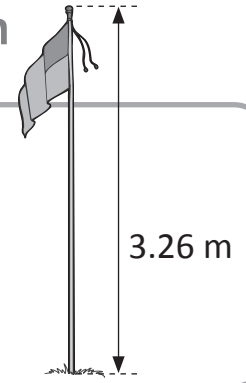

We can use decimal notation to record lengths.

This flag pole is 326 centimetres tall and can be written as 3 metres and 26 centimetres or 3.26 metres in decimal notation.

1 Match the following measurements. The first one has been done for you.

1 m 65 cm	267 cm	9.87 m
2 m 67 cm	987 cm	2.61 m
1 m 69 cm	261 cm	1.65 m
9 m 87 cm	169 cm	1.69 m
2 m 61 cm	165 cm	2.67 m

Connections: A line connects '1 m 65 cm' to '165 cm'. Another line connects '165 cm' to '1.65 m'.

2 Record the total length of both lines in each question in decimal notation:

a

m

b

m

c

m

Units of length – length and decimal notation

3 In this activity, you are going to make a paper aeroplane to fly and mark the distance it has flown. You will need one sheet of A4 paper, a ball of string and a metre ruler.

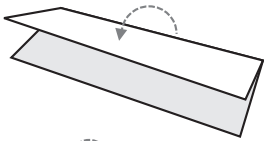

1 Fold the sheet of A4 paper in half lengthwise. Crease the folded end. Unfold the paper and lay it on a flat surface.

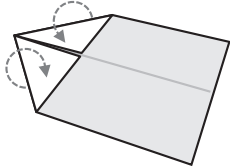

2 Fold the right top corner to the centre line. Crease the diagonal fold. Repeat for the left top corner.

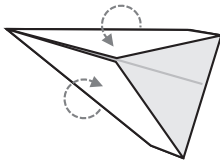

3 Fold the new right top corner to the centre line. Crease the folded end. Repeat for the new left top corner.

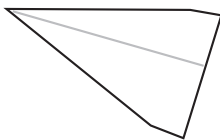

4 Turn the aeroplane over and fold the sheet lengthwise, inward, along the centre line. Crease the folded end.

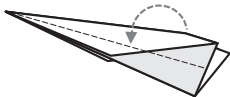

5 Fold the top flap down so that its front touches the bottom of the 'plane'. Crease the folded end.



6 Turn the paper over, fold and crease the other flap as you did in step 5.



7 Lift the flaps to create the wings.

a Now that you have made a paper aeroplane, work in a small group to see who can throw their plane the furthest. Every time one of your group flies their aeroplane, place the string from the starting position to where it lands. Cut the string to the exact measurement and place it next to a metre ruler to work out the distance. Record your distances in the table below:

Name	Distance in centimetres	Distance in metres

b Whose aeroplane went the furthest? _____



Getting ready

This is a game for 2 players. Players need a different coloured pencil each and a copy of this page. You may wish to make extra copies to play again.



copy



What to do

The object of this game is to be the player with the longest total of all their lines. Player 1 connects the black dots vertically. Player 2 connects the white dots horizontally.

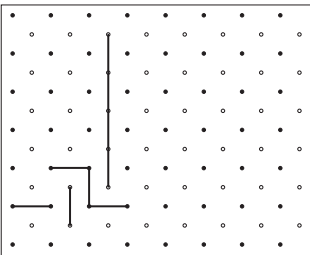

Neither player can go diagonally. Players may only connect 2 dots at a time. Lines can't cross over. You can block your opponent by connecting dots in front of their line. Look at the example to the left. When the grid is full, each player totals all their lengths.

The length between dots is 2 cm. This might vary due to printer settings, but use the length of 2 cm for this game.

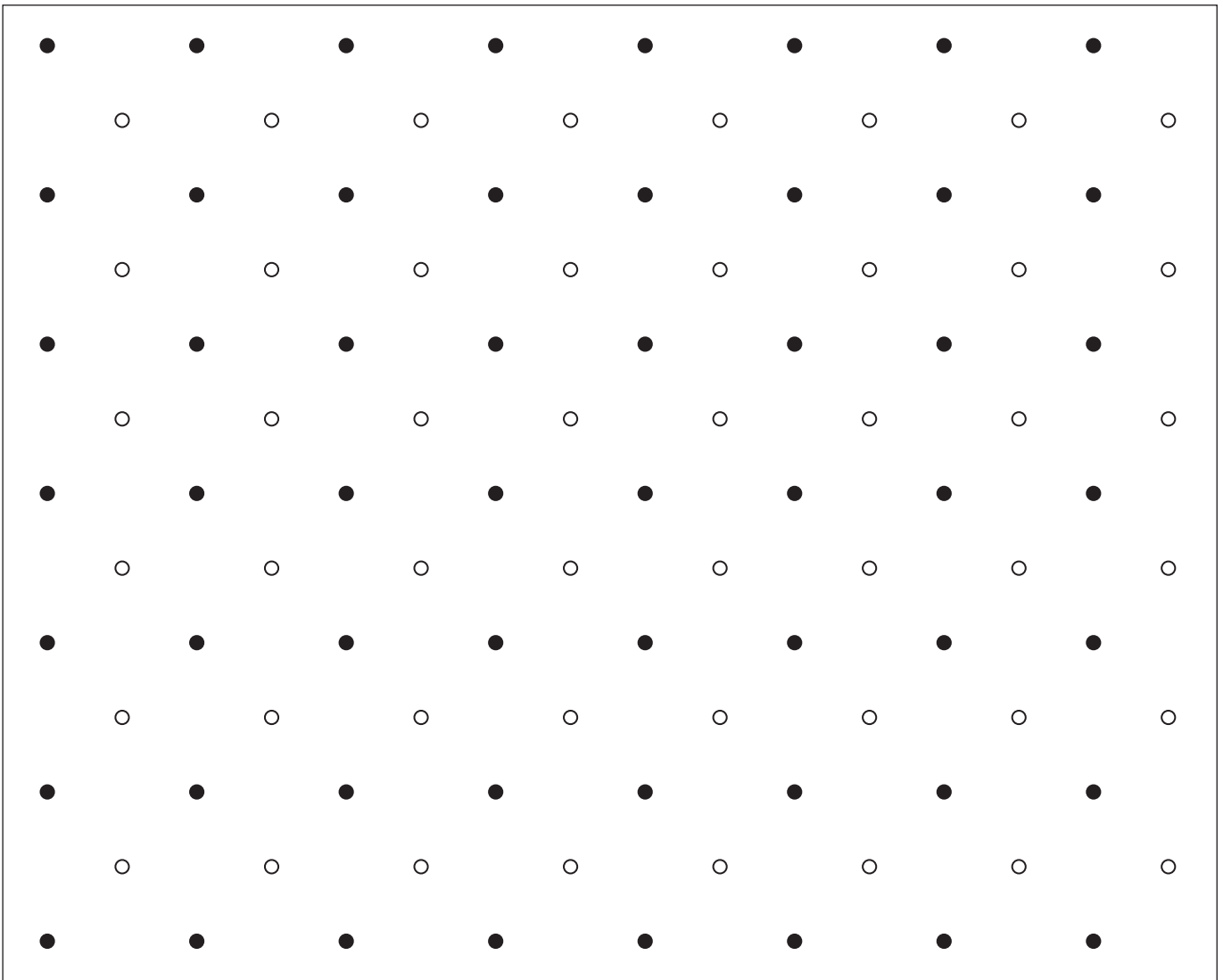

Area – square centimetres

An area is the amount of surface on a shape or object.
 Small areas are measured in square centimetres.
 We write this as cm^2 for short.

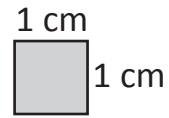

1 Calculate the area of each of the following shapes by counting the square centimetres.*

a	b	c
<input type="text"/> cm^2	<input type="text"/> cm^2	<input type="text"/> cm^2

d	e	f
<input type="text"/> cm^2	<input type="text"/> cm^2	<input type="text"/> cm^2

g	h
<input type="text"/> cm^2	<input type="text"/> cm^2

**Not drawn to scale.*

2 Using the grid paper below, create 4 different shapes that have an area of 6 cm^2 .*

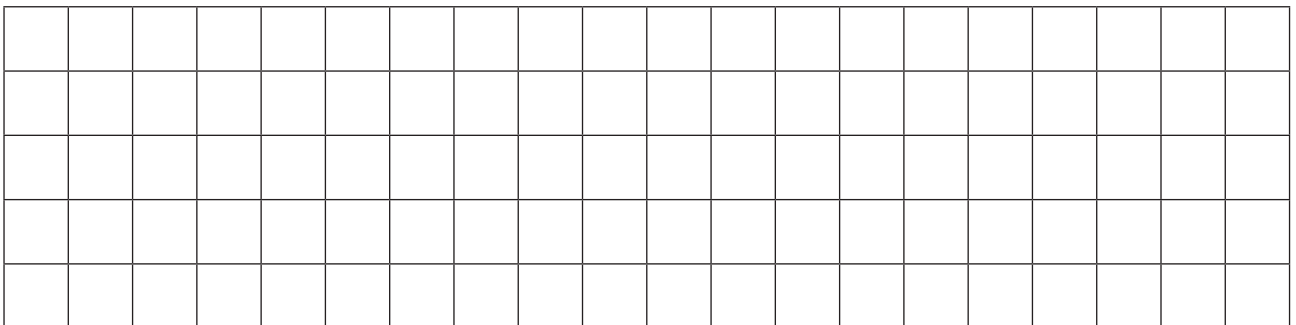

**Not drawn to scale.*

Area – square centimetres

3 Count the square centimetres that each shape is made up of.

a

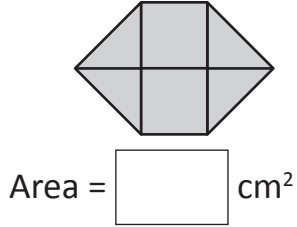

b

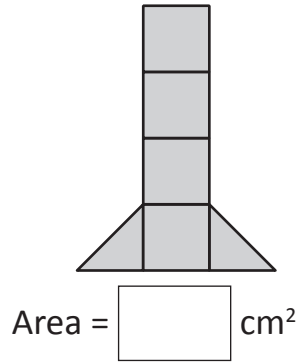

c

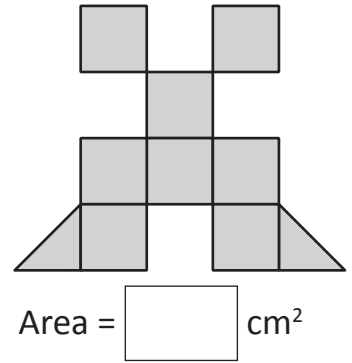

4 Measure the area of your hand on the grid below by counting how many squares it takes up. Is it easier to measure with your fingers stretched out or together?

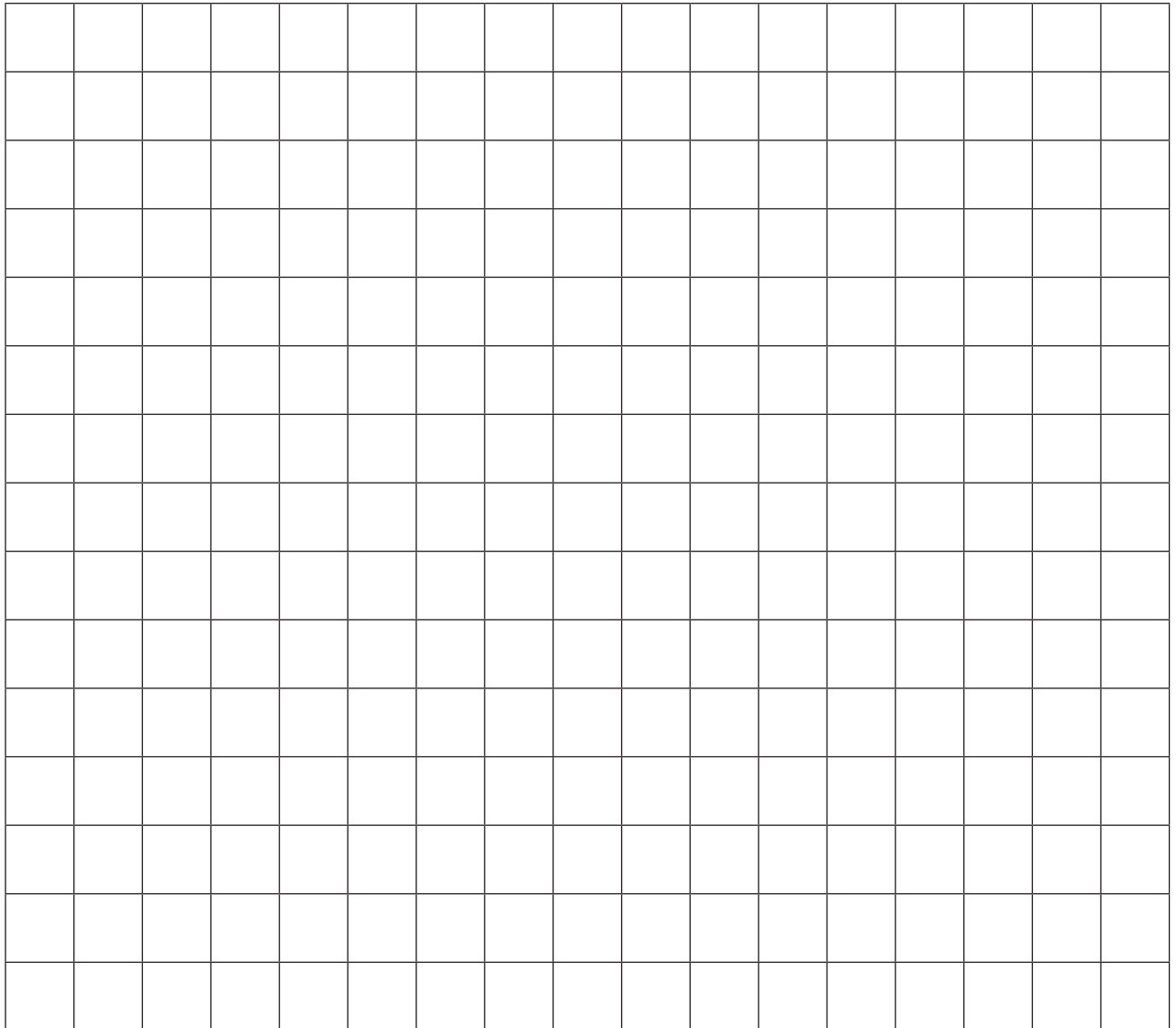

My hand is square centimetres.

Area – square metres

When we need to find the areas of large spaces we use square metres.
The symbol for square metres is m^2 .

- 1 In groups, stick pieces of newspaper together to make a square that is 1 metre long and 1 metre wide.



How many children can fit inside 1 square metre?

- 2 Rewrite these measurements using the short form:

a 7 square metres =

b 3 square metres =

c 10 square metres =

d 11 square metres =

e 19 square metres =

f 21 square metres =

- 3 Which unit of measurement (cm^2 or m^2) would you use to find the area of:

a a mobile phone =

b a football pitch =

c an A4 piece of paper =

d your bed =

e a dictionary =

f the top of a shoe box =

- 4 Measure the items in the table below and place a tick in the column that matches:

The area of:	Less than $1 m^2$	Area about $1 m^2$	More than $1 m^2$
a the classroom door			
b the calendar			
c the whiteboard			
d the computer screen			



What to do



Solve these area challenges based on the dimensions on each shape.

1 Look at this rectangle. It has been divided into 3 equal sections.

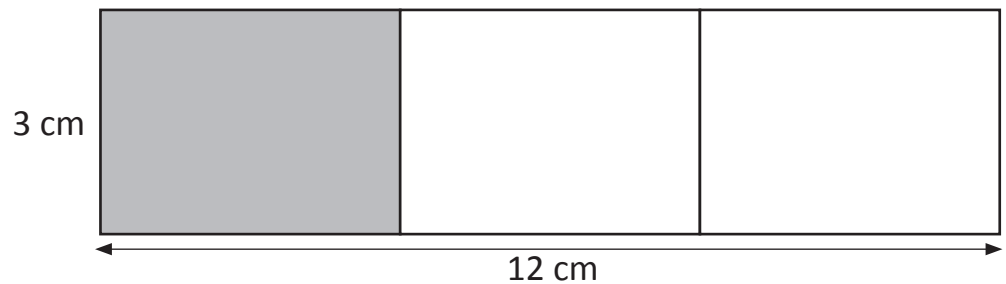

a Work out the area of the shaded section.

b Now work out the area of the unshaded sections.

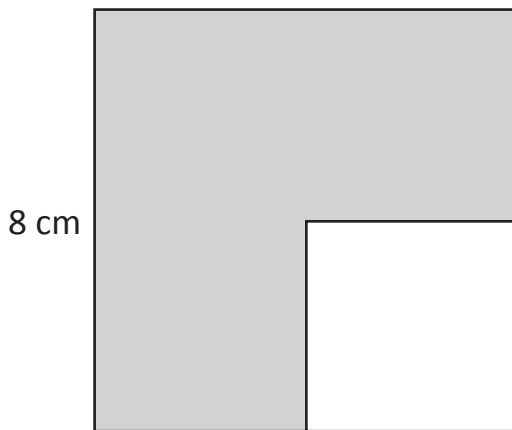

*Not drawn to scale.

2 This square* has $\frac{1}{4}$ painted white. What is the area of the grey section? Show your working.



Getting ready



For these problems, you will need a copy of this page. Cut out the set of 7 tangram pieces below. Colour each piece so that:



copy

- 1 square: yellow
- 2 small triangles: red
- 1 medium triangle: blue
- 2 large triangles: green
- 1 parallelogram: orange

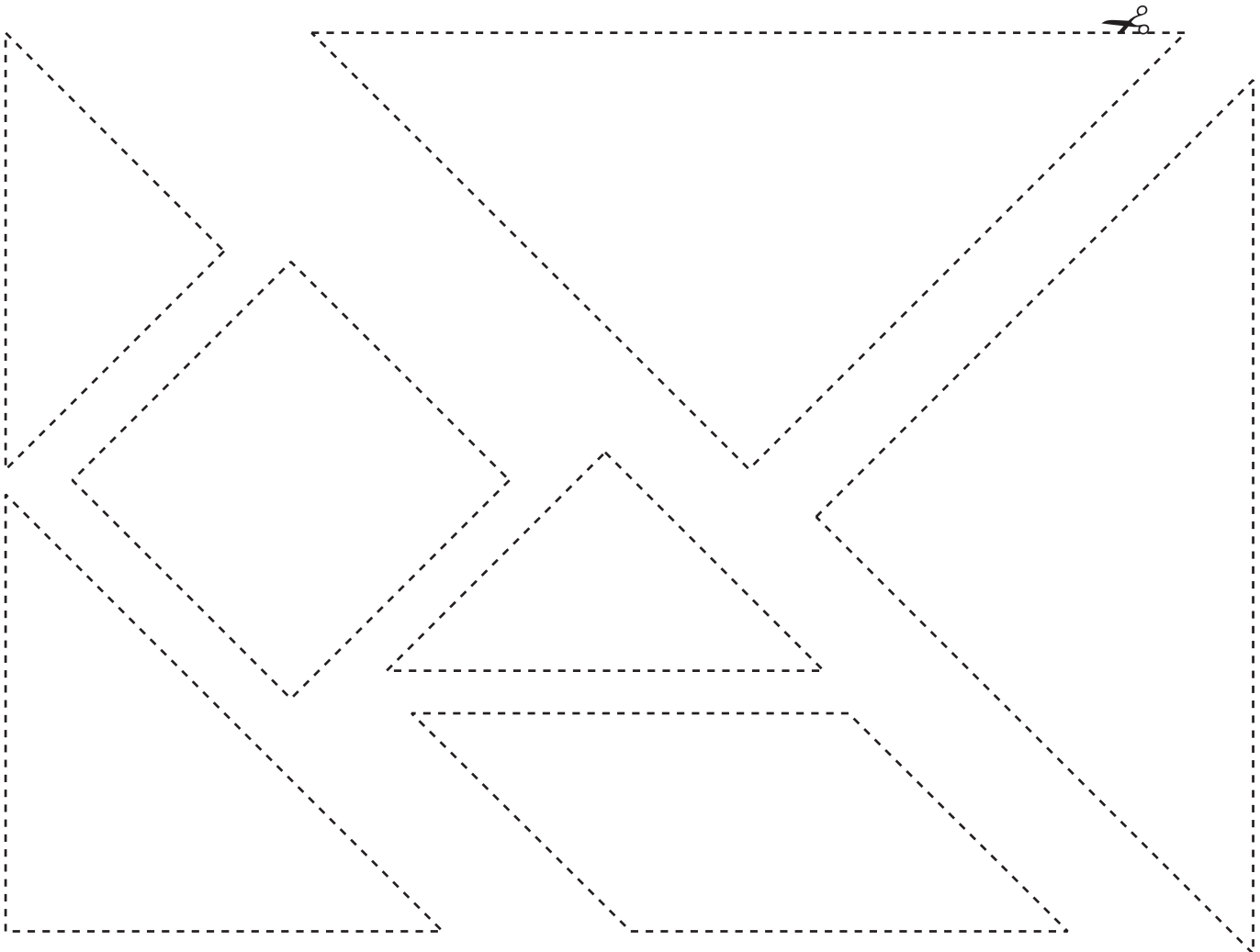

What to do



For each problem on page 15, work out the area of the square made up from tangram pieces. Your only clue is that the yellow square is 1 square unit. Stick your pieces together on a piece of paper.



What to do



Problem 1

Make a square with the blue triangle and the 2 red triangles.

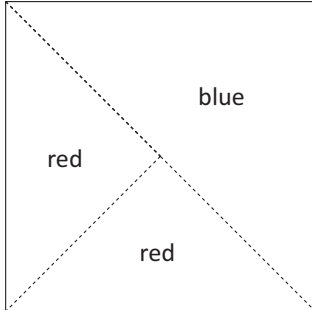

a What is the area of this new square? square units

b How do you know?

Problem 2

Make another square, this time using all 7 tangram pieces.

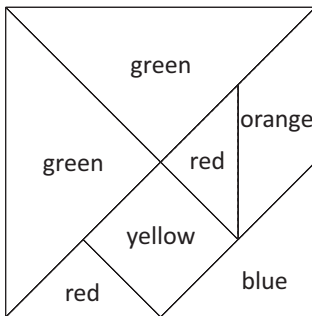

a What is the area of this new square? square units

b How do you know?

Volume and capacity – litres

Capacity refers to how much liquid a container can hold. Capacity can be measured in litres. We use the symbol L. Next time you go to the supermarket, look out for all the different items that have L for litres on the label. For example, milk cartons are often sold in litres.



1 Here is a selection of containers. Work out how many times each container can be filled from a 1 litre carton, such as a milk carton.



a

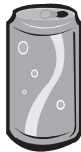

b



c



d



e



f



g



h

2 Use a 1 litre carton to estimate and measure the capacity of these containers in litres.



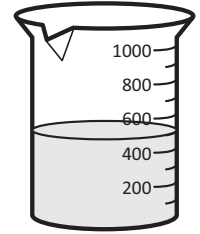

	a waste bin	b saucepan	c watering can	d bucket
Container				
Estimate				
How many litres?				

Volume and capacity – millilitres





To measure the capacity of smaller containers we use millilitres. The symbol for millilitres is mL. There are 1 000 mL in 1 litre. This litre jug is filled half way so it contains 500 mL of liquid.



1 How many of each container is needed to fill a 1 litre jug?

Container size	a mug 250 mL 	b glass 200 mL 	c egg cup 50 mL 	d a raindrop 1 mL 
Number needed to fill a 1 litre jug				

2 Order these containers from smallest to largest according to their capacity.

Container	a 	b 	c 	d 	e 
Order					

3 What is the most appropriate unit of capacity for each of these objects – millilitres (mL) or litres (L)?

a 

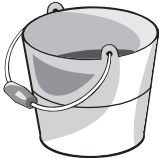
b 

c 

d 

e 

f 

Volume and capacity – millilitres

4 Label each of these containers with the amount of water in each:

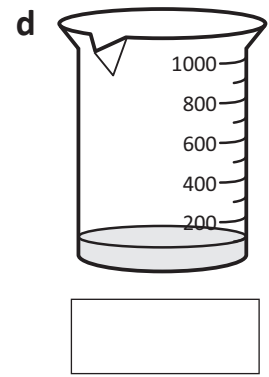
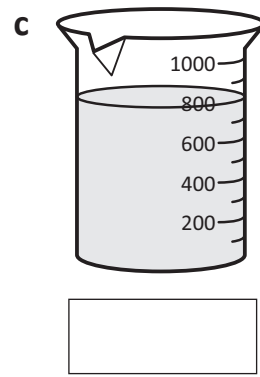
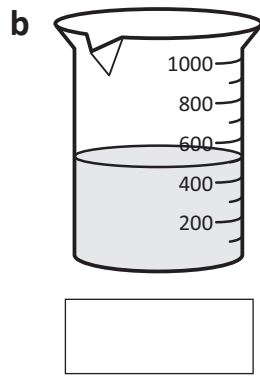
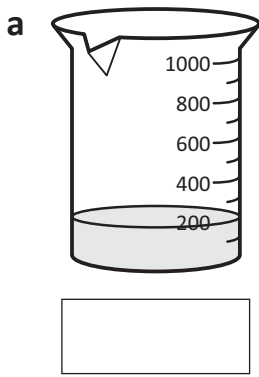

5 Answer the questions based on the amount of water in the containers above.

- a Which container has the most liquid in it? _____
- b Which container has the least liquid in it? _____
- c How much more liquid is there in container c than in container a? _____
- d Which three containers, when added together, would not overflow? _____

6 Mark the level of liquid in these jugs according to each problem.

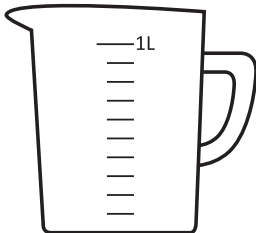
a  Bec pours herself a glass of orange juice from this jug that was full to the 1 litre mark. If the glass she uses is 300 mL, how much is left in the jug?

b  Cam is mixing cordial for a party. He pours in 200 mL of cordial and then adds twice as much water. How much mixed cordial is now in the jug?

Volume and capacity – measuring volume with cubic centimetres

Volume is the amount of space that an object takes up.

To measure volume we use cubic centimetres.

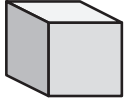

One cubic centimetre is 1 cm long, 1 cm wide and 1 cm high.
The symbol we use for cubic cm is cm^3 .

$$1 \text{ cm} \times 1 \text{ cm} \times 1 \text{ cm} = 1 \text{ cm}^3$$

- 1** Use centicubes or base 10 ones to create the following models. Then count the number of cubes to work out the volume of each model.

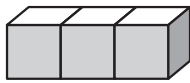

a cubic centimetres

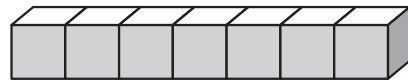

b cubic centimetres

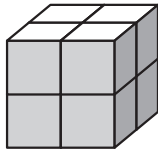

c cubic centimetres

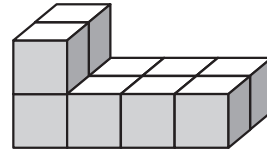

d cubic centimetres

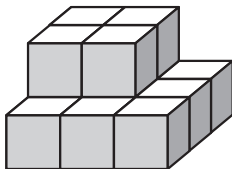

e cubic centimetres

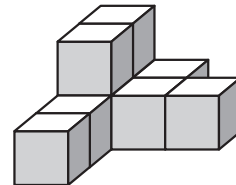

f cubic centimetres

- 2** For this next task, you will need 27 cubes.

a Use all 27 cubes to make a model that is 3 cubes long and 3 cubes wide.

b What is the volume of a model that is 4 cubes long, 2 cubes wide and 2 cubes high?

cubic centimetres



You can use cubes to help with these problems.



1 How many more cubes are needed to make each model a total volume of 64 cubic centimetres?

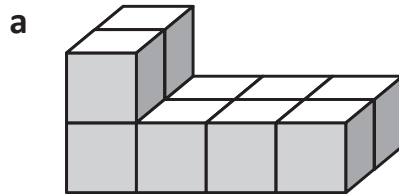

more cubes

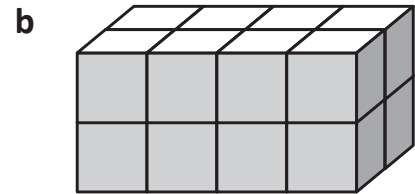

more cubes

2 How many more cubes are needed to make each model a total volume of 27 cubic centimetres?

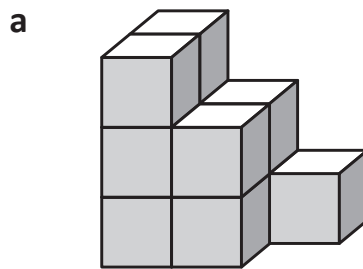

more cubes

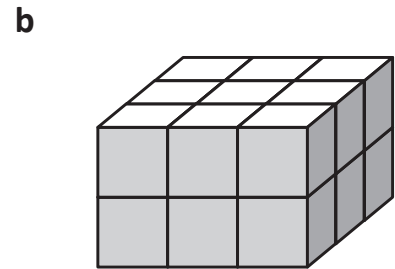

more cubes

3 How many more cubes are needed to make each model a total volume of 125 cubic centimetres?

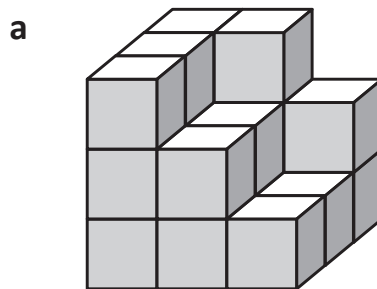

more cubes

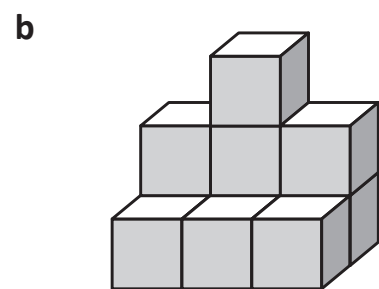

more cubes

Mass – kilograms

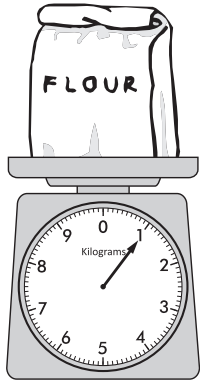

When we measure how heavy something is, we are looking at the mass of an object. We measure mass in kilograms. We say kilo for short and write it as kg.

Flour is something that is sometimes sold in 1 kg bags.

This scale is one that most people use when they are cooking. You might have one in your kitchen at home.

- 1** Use a set of balancing scales to test the mass of the following items. Ring the items that weigh less than 1 kg and underline the items that weigh more than 1 kg.

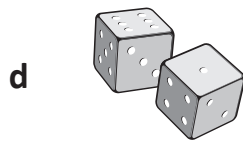
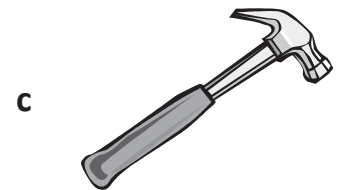

- 2** For this next task, you will need a class set of exercise books that are all the same.

- a Work with a partner to estimate how many books are needed to balance 1 kg. In the table below, record your team's guess, then ask two other teams and record their guesses.

	Team names	Number of books	More or less than 1 kg
1			
2			
3			

- b After you have found out the number of books that will balance or get the closest to 1 kg, write **more** or **less** next to each guess. Who was the closest?

Mass – kilograms

3 How much less than 1 kg are the following weights?

a 500 g

b 750 g

c 600 g

d 150 g

e 250 g

f 400 g

4 Ring the 3 weights that combine to give a mass of 1 kg:

a 300 g 400 g 100 g 500 g = 1 kg

b 200 g 150 g 600 g 200 g = 1 kg

c 220 g 480 g 550 g 300 g = 1 kg

5 When we buy fruit and vegetables, we usually pay by the kilogram. Can you think why this is?

6 Search through some supermarket catalogues and find out the cost of these items per kilogram:



per kg

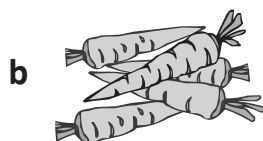

per kg



per kg

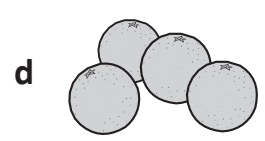

per kg

7 Based on the price per kilogram in question 6, work out the total cost of my shopping if I bought the following:

2 kg of apples = _____

1 kg of carrots = _____

3 kg of oranges = _____

Total cost = _____

Use a calculator.
Write the subtotal next to each item.



CHECK

Mass – grams

We use grams to measure items that are less than 1 kilogram. We use g for grams.

1 kilogram = 1 000 grams

$\frac{1}{2}$ kilogram = 500 grams

1 Write each mass in grams:

a seventy five grams

b eighty two grams

c five hundred grams

d one thousand grams

e Ring the amount that is the same as 1 kilogram.

f Underline the amount that is the same as half a kilogram.

2 Which unit of mass would you use for each item – kilogram (kg) or gram (g)?

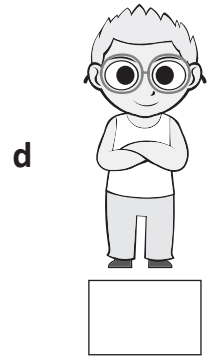
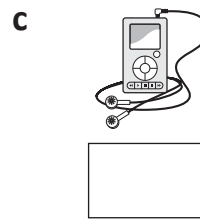
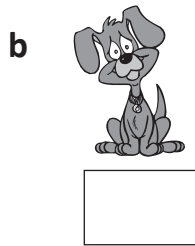
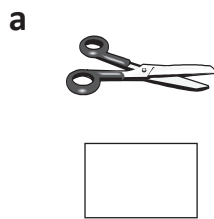

3 Estimate then measure the mass of each item:

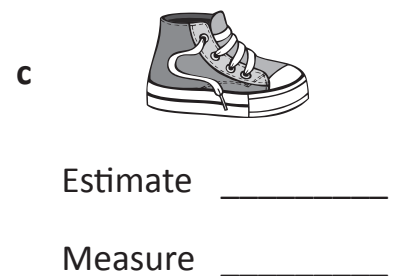
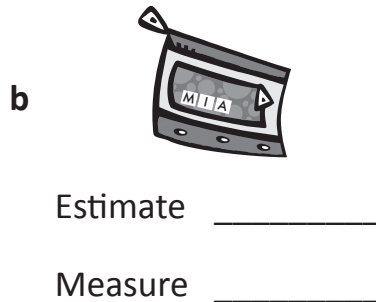
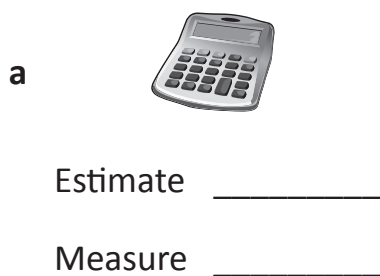

4 Find items around your classroom that fit into each category. Try and get them as close as possible to the mass in each column.

Item	About 100 g	About 200 g	More than a kg
a			
b			
c			

Mass – grams

5 Use supermarket catalogues to find out the mass of these items:

a



b



c



6 If the length of this line represents 1 kg and the marker in the middle is 500 g, where would these items go? Draw a line to connect them to the right place:

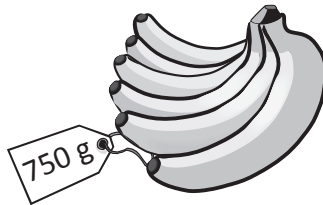
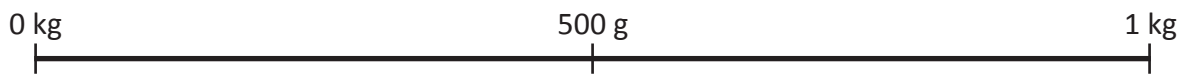

7 Decide whether the combined mass of the items pictured above weighs more or less than 1 kg.

- a baked beans and bananas more or less
- b tub of yogurt and an egg more or less
- c bananas and the yogurt more or less
- d egg and bananas more or less

8 Write the mass of each type of fruit:

a

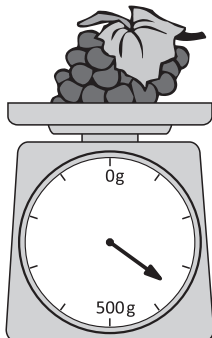

b

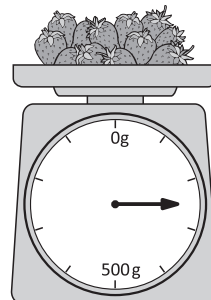



What to do



Find the mass of each of these items.

a

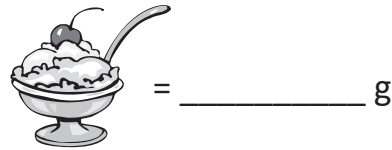
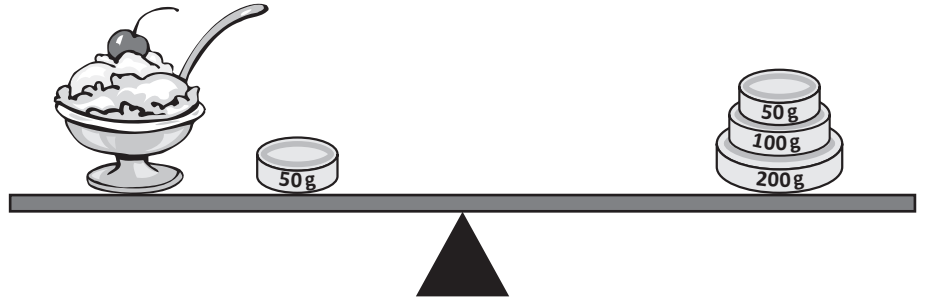

b

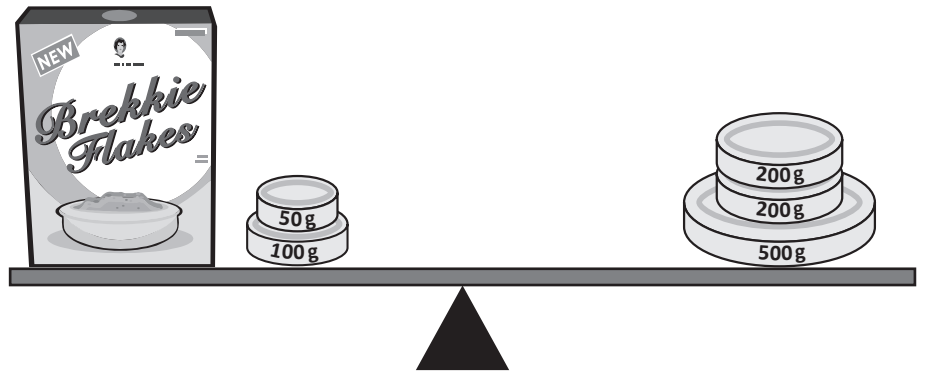

c

